

MODEL **SAGM 06 220**  
 VOLTAGE **6**  
 CAPACITY **220Ah @ 20Hr**  
 MATERIAL **Polypropylene**  
 BATTERY **VRLA AGM / Non-Spillable / Maintenance-Free**  
 COLOR **Maroon**  
 WATERING **No Watering Required**  
 IEC 61427 **8+ Years Life**



## 6 VOLT

### PHYSICAL SPECIFICATIONS

MODEL NAME	TERMINAL TYPE <sup>D</sup>	DIMENSIONS <sup>B</sup> INCHES (mm)			WEIGHT <sup>F</sup> LBS. (kg)	HANDLES	INSTALLATION ORIENTATION
		LENGTH	WIDTH	HEIGHT <sup>C</sup>			
SAGM 06 220	M8/LT				68 (31)	Embedded	Horizontal and Vertical
		10.30 (262)	7.06 (179)	10.73 (273)			

### ELECTRICAL SPECIFICATIONS

VOLTAGE	CAPACITY <sup>A</sup> AMP-HOURS (Ah)					ENERGY (kWh)	INTERNAL RESISTANCE (mΩ)	SHORT CIRCUIT CURRENT (amps)
	10-Hr	20-Hr	48-Hr	72-Hr	100-Hr			
6						100-Hr	1.9	3250
	190	220	228	231	235	1.32		

### CHARGING INSTRUCTIONS

CHARGER VOLTAGE SETTINGS (AT 77°F/25°C)					
SYSTEM VOLTAGE	6V	12V	24V	36V	48V
Maximum Charge Current (A)	20% of C <sub>20</sub>				
Absorption Voltage (2.40 V/cell)	7.20	14.40	28.80	43.20	57.60
Float Voltage (2.25 V/cell)	6.75	13.50	27.00	40.50	54.00

Do not install or charge batteries in a sealed or non-ventilated compartment. Constant under or overcharging will damage the battery and shorten its life as with any battery.

### CHARGING TEMPERATURE COMPENSATION

ADD	SUBTRACT
0.005 volt per cell for every 1°C below 25°C 0.0028 volt per cell for every 1°F below 77°F	0.005 volt per cell for every 1°C above 25°C 0.0028 volt per cell for every 1°F above 77°F

### OPERATIONAL DATA

OPERATING TEMPERATURE	SELF DISCHARGE
-4°F to 122°F (-20°C to +50°C). At temperatures below 32°F (0°C) maintain a state of charge greater than 60%.	Less than 3% per month depending on storage temperature conditions.

### RECYCLE RESPONSIBLY



### STATE OF CHARGE MEASURE OF OPEN-CIRCUIT VOLTAGE

PERCENTAGE CHARGE	CELL	6 VOLT
100	2.14	6.42
75	2.09	6.27
50	2.04	6.12
25	1.99	5.97
0	1.94	5.82

## SOLAR CYCLE-LIFE

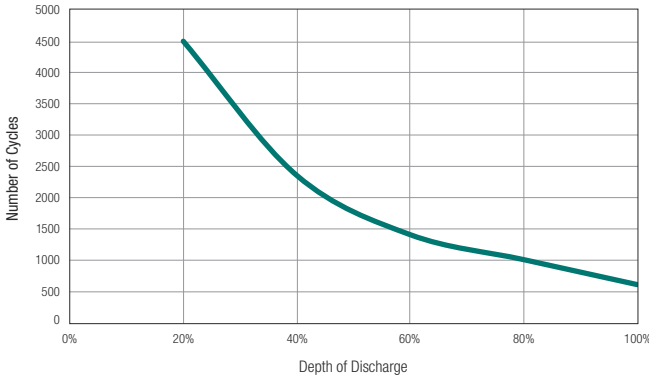

## PERCENT CAPACITY VS. TEMPERATURE

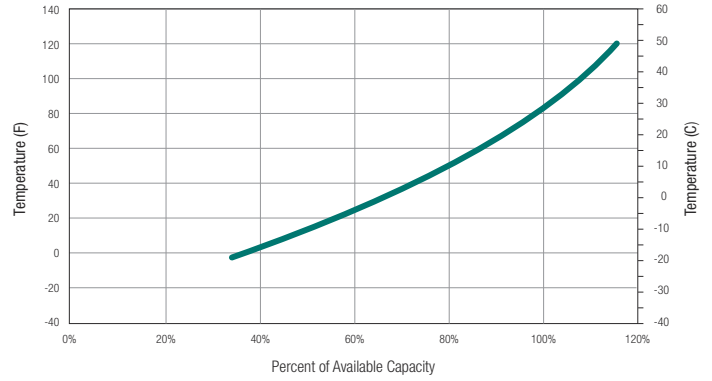

## SELF DISCHARGE VS. TIME<sup>E</sup>

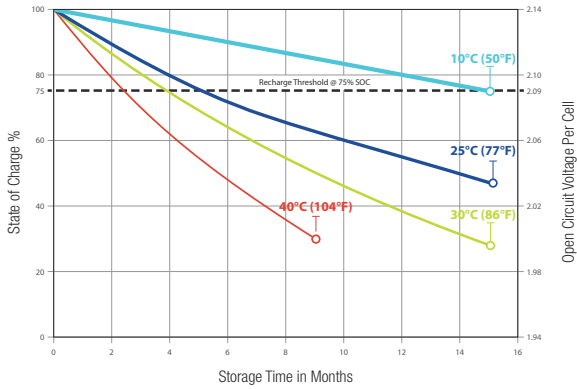

## TROJAN SAGM 06 220 PERFORMANCE

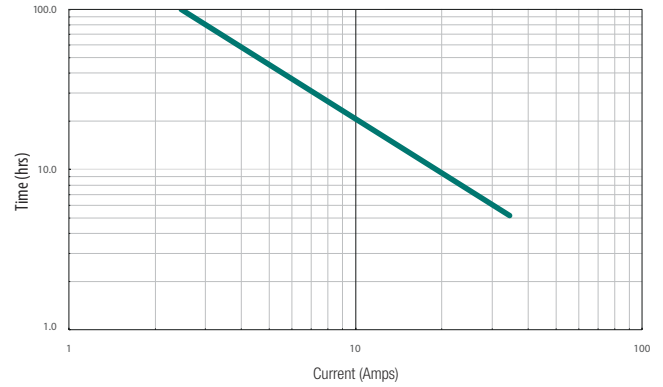

## BATTERY DIMENSIONS (shown with M8, height is 12.07 (307) with LT)

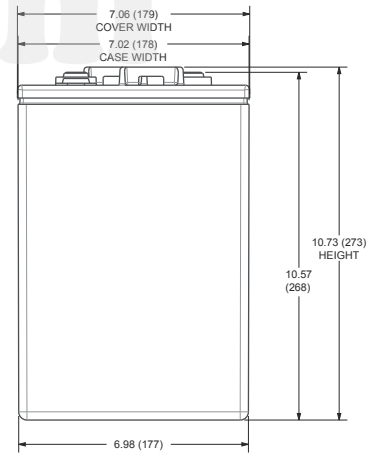
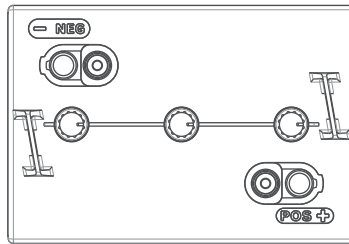
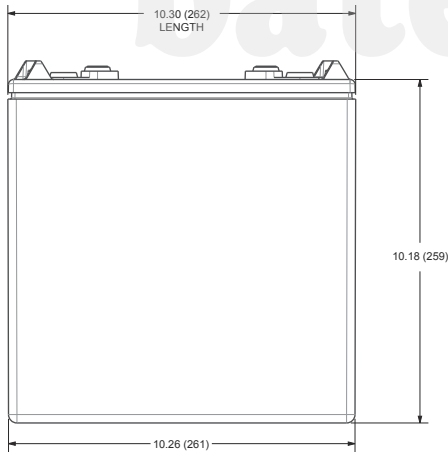

## TERMINAL CONFIGURATIONS<sup>D</sup>

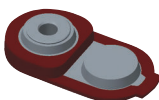
15	M8	M8
	<b>Battery Height with Terminal in Inches (mm)</b> 10.57 (268)	<b>Torque Values in-lb (Nm)</b> Bolt: 85 – 90 (10 – 11)

15	M8	M8 WITH LT ADAPTER (ADAPTER PROVIDED BUT NOT INSTALLED)
	<b>Battery Height with Terminal in Inches (mm)</b> 12.07 (307)	<b>Torque Values in-lb (Nm)</b> Connection to M8: 85 – 90 (10 – 11) Connection to LT: 65 – 75 (7.5 – 8.5)
	<b>Bolt Size</b> M8 x 1.25	

- A. The amount of amp-hours (Ah) a battery can deliver when discharged at a constant rate at 86°F (30°C) for all rates and maintain a voltage above 1.75 V/cell. Capacities are based on peak performance.
- B. Dimensions may vary depending on type of handle or terminal. Batteries should be mounted with 0.5 inches (12.7 mm) spacing minimum.

- C. Height taken from bottom of the battery to the highest point on the battery. Heights may vary depending on type of terminal.
- D. Terminal images are representative only.
- E. A boost charge should be performed every 6 months when batteries are in storage.
- F. Weight may vary.



Designed in compliance with applicable BCI, DIN, BS and IEC standards.  
Tested in compliance to BCI and IEC standards.



800.423.6569 / +1.562.236.3000 / trojanbattery.com

SAGM\_06\_220\_DS\_021319

© 2019 Trojan Battery Company, LLC. All rights reserved. Trojan Battery Company is not liable for damages that may result from any information provided in or omitted from this publication, under any circumstances. Trojan Battery Company reserves the right to make adjustments to this publication at any time, without notice or obligation.